



MUD FLAP PRODUCTS

Heavy-gauge spring loaded Light Bars and Mud Flap Hangers available in OEM grade, stainless steel, chrome, black powder coat.

Product Information - Mud Flap Hangers & Light Bars

Bolt Patterns

All American Chrome Mud Flap Hangers come in one of two industry-standard bolt patterns; 1.125" (1 1/8") or 2.50" (2 1/2"). The term 'bolt pattern' refers to the spacing of the two bolts that extend from the end plate of the product, and are used to secure the product to the frame of the vehicle. Many trucks have pre-drilled holes for mounting Mud Flap Hangers, and the easiest mounting method is to use these existing holes to secure the product to the truck frame. The distance between the bolts is measured between the center of each bolt to the opposite bolt as shown below.

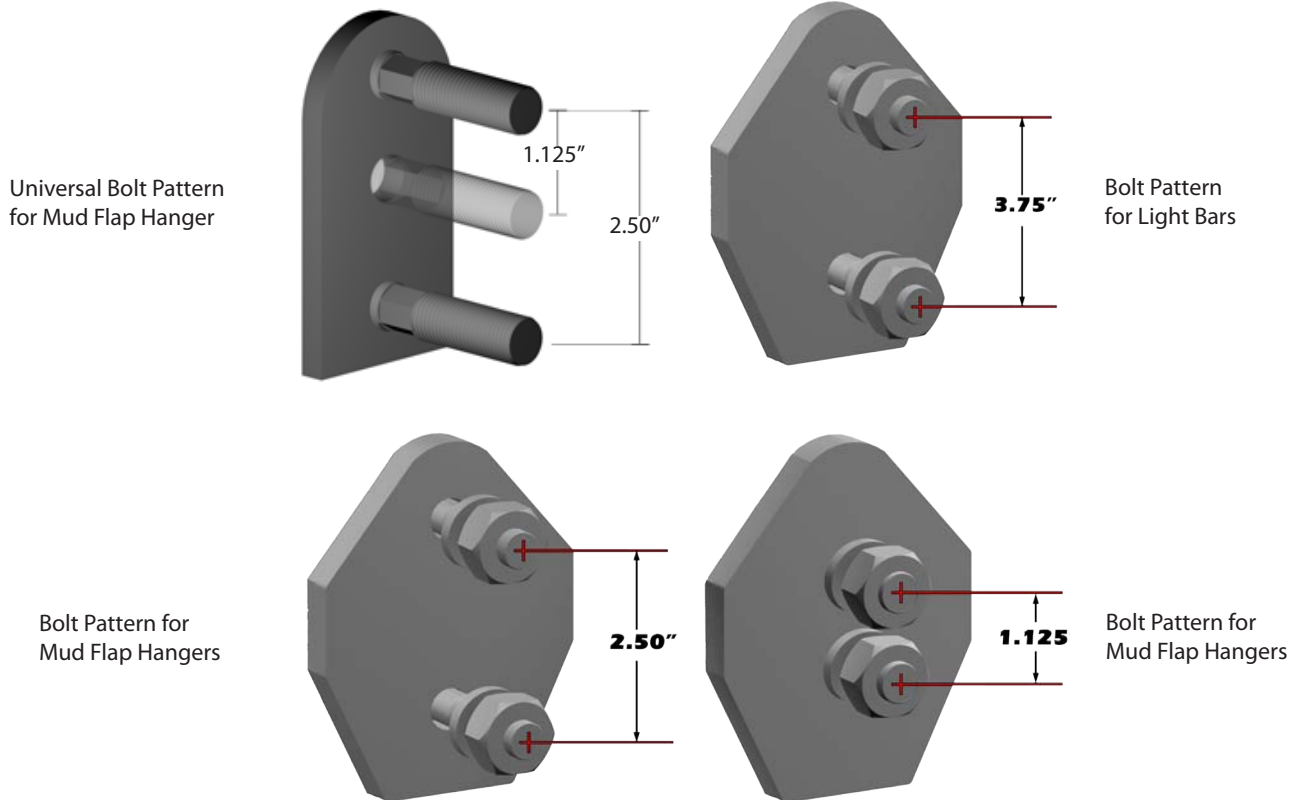

Spring-Loaded vs Standard

American Chrome Light Bars are available in Standard and Spring-Loaded Configurations. Spring-Loaded Light Bars are designed to bend when hit, and the heavy-duty internal springs snap the unit back into place when the obstruction is clear. Depending on the severity of the impact, the product may show some minor physical damage, but is designed to offer continued service until the unit can be replaced.

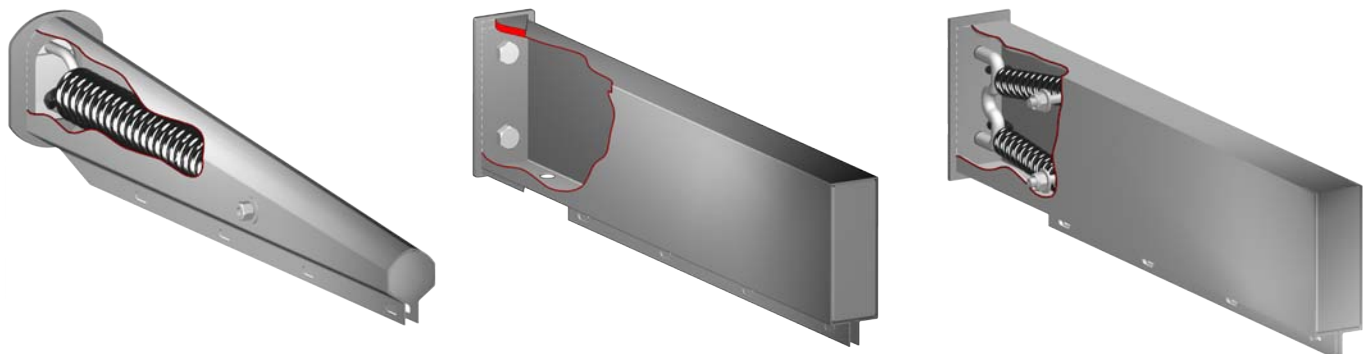

Spring-Loaded Mud Flap Hangers - Spring-Loaded Mud Flap Hangers feature one spring under tension. These springs are powerful enough to return the Hanger to its original position after an impact. Constructed of heavy-gauge Stainless Steel.

Standard Light Bars - Standard Light Bars are constructed of heavy-gauge Stainless Steel, with two internal bolts welded to a thick slab steel end plate to provide a secure attachment point.

Spring-Loaded Light Bars - Spring-Loaded Light Bars feature two smaller springs under tension. These springs are powerful enough to return the Light Bar to its original position after an impact. Constructed of heavy-gauge Stainless Steel.

Product Information - Mud Flap Weights

Stainless - American Chrome's Stainless Steel Mud Flap Weights are forged from a massive slab of high-grade stainless steel to resist rust and corrosion. Designed to last.

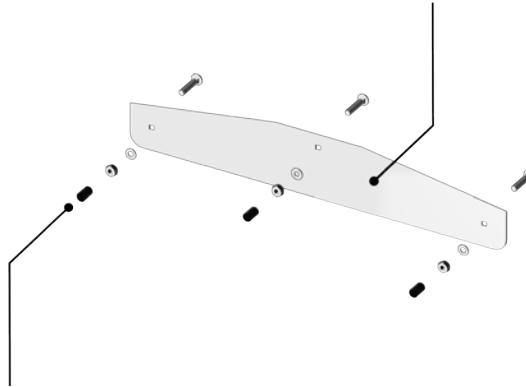

Hardware Mount - Hardware-Mounted Mud Flap Weights feature several square holes, with carriage bolts going through the weight and the mud flap. The provided washers and nuts are used to complete the assembly. This is a very secure way to mount hardware to a mud flap, and is less prone to breakage due to road debris and hazards.

Hardware Mount

Using Stainless Steel, the Hardware-Mount-Style Mud Flap Weights are the best option for secure mounting and less chance of breakage.

Weld Stud Mount

The Weld Stud Mount style Mud Flap Weights are designed to be less likely to attract dirt and debris.

Super Premium Chrome - Nothing beats the classic sparkle and shine of genuine chrome, and no chrome finish lasts as long or is as durable as our exclusive Super Premium® Chrome finish. Chrome Mud Flap Hangers are forged from heavy-weight steel for durability.

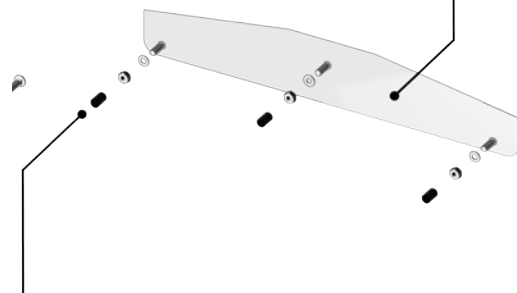

Weld Stud Mount - Weld Stud Mount Weights feature three welded studs with threads, located on the rear of the unit. The studs go through the mud flap, and are secured using the provided washers and nuts. This mounting style provides the cleanest look.