



NUT COVERS

North America's largest selection of OEM-grade lug nut covers. ABS chrome, stainless steel, and chrome steel available in all sizes and styles.

Product Information - Nut Covers

ABS Chrome Nut Cover

Internal Threads - Threads molded into the body of the ABS Nut Cover mate with the threads on the exposed stud above the lug nut. Typically it requires at least 3 complete turns to assure a tight fit.

Lug Nut - ABS Nut Covers come in two basic sizes. 33mm Nut Covers fit lug nuts on hub piloted wheels, and 1.5" Nut Covers fit lug nuts on stud piloted wheels. The amount of exposed thread above the lug nut is the only consideration when choosing Twist-On or Push-On styles.

The Twist-On style provides the most secure attachment, but Push-On is useful when limited amount of thread is available.

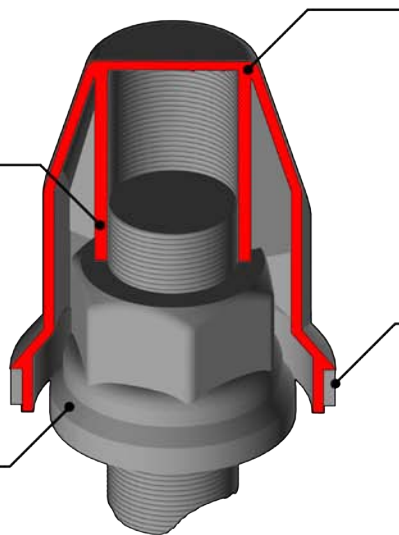

Twist-On Style

ABS Body - Nut Covers are molded from a high-strength automotive plastic called ABS or PC ABS. This material is impervious to rust or corrosion, and will never chip or peel. ABS offers extreme durability and resistance to the elements, at an affordable price.

Infinity® ABS Nut Covers are ideal for vocational applications, where wheels will be exposed to extreme environments.

Notched Flange - Twist-On ABS Lug Nut Covers featuring the notched flange design are designed specifically for use with our line of ABS Hub Covers. The notches work in concert with the locking mechanism designed into the ABS Hub Covers to provide a secure fit. ABS Nut Covers with these notched flanges will work with all standard Twist-On applications as well, and are available as a decorative enhancement on some of our ABS Nut Covers.

Push-On ABS Nut Covers are available with both notched and smooth flanges, and work equally well with any of our ABS Hub Covers.

Internal Ribs - Ribs molded into the body of the ABS Nut Cover provide a friction fit against the flat sides of the lug nuts. Repeatedly installing and removing the ABS Nut Cover can wear down the surface and reduce the tension against the lug nut, resulting in lost or loose nut covers.

Lug Nut - ABS Nut Covers come in two basic sizes. 33mm Nut Covers fit lug nuts on hub piloted wheels, and 1.5" Nut Covers fit lug nuts on stud piloted wheels. The amount of exposed thread above the lug nut is the only consideration when choosing Twist-On or Push-On styles.

The Twist-On style provides the most secure attachment, but Push-On is useful when limited amount of thread is available.

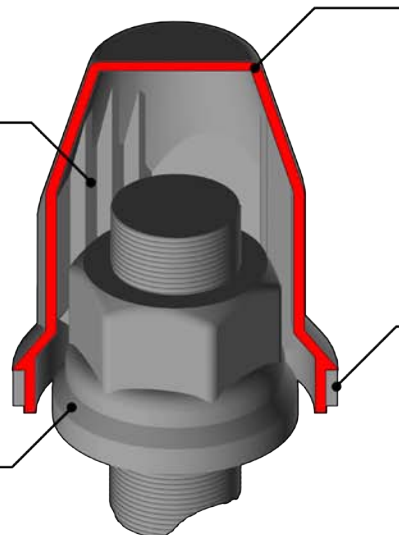

Push-On Style

ABS Body - Nut Covers are molded from a high-strength automotive plastic called ABS or PC ABS. This material is impervious to rust or corrosion, and will never chip or peel. ABS offers extreme durability and resistance to the elements, at an affordable price.

Flange - ABS Nut Covers are typically offered "with Flange" and "without Flange". 33mm lug nuts for Hub-Piloted wheels require a Nut Cover with flange for a proper fit. 1.5" lug nuts do not require a flanged Nut Cover, but they are available as a decorative option.

Product Information - Nut Covers

Chrome & Stainless Steel Nut Cover

Stud - Using a properly designed and installed Lug Nut Cover not only beautifies the wheels, it protects the threads on the stud from rust, corrosion, and dirt, making it easier to remove and maintain the wheels.

Dimple - There are usually three dimples placed around the exterior of the Nut Cover. These dimples provide the 'friction-fit' that keeps the Nut Cover tightly in place. The size of a nut cover is determined by measuring from the inside surface of the dimple to the opposite 'flat' surface of the Nut Cover.

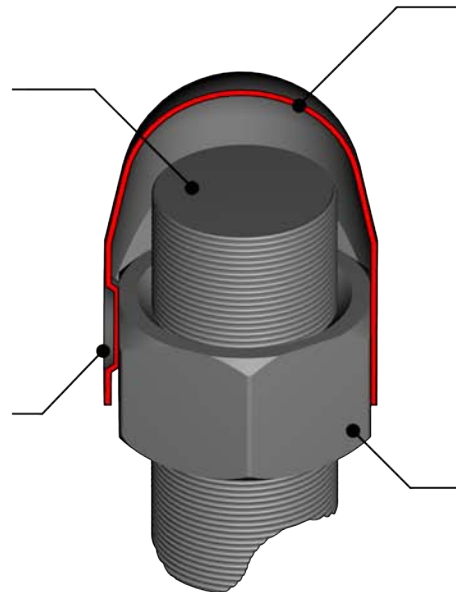

SuperPremium® Chrome - Quality Lug Nut Covers are manufactured from heavy-gauge steel, then plated using our unique SuperPremium® Chrome plating process. Our OEM-grade Nut Covers are redesigned to provide years of service without rusting or corroding, and the thick steel resists dents and dings better than the cheap imitators.

Many of our popular models are also available in heavy-duty 304 stainless steel, which is guaranteed never to rust.

No Flange - 1.5" Lug nuts (used on stud-piloted wheels) do not have an integral flange washer, and do not need a flanged Nut Cover for a proper fit. However, many customer like the look of flanged Nut Covers, and these are available as a decorative option on many of our models.

Without Flange

Stud - Using a properly designed and installed Lug Nut Cover not only beautifies the wheels, it protects the threads on the stud from rust, corrosion, and dirt, making it easier to remove and maintain the wheels.

Dimple - There are usually three dimples placed around the exterior of the Nut Cover. These dimples provide the 'friction-fit' that keeps the Nut Cover tightly in place. The size of a nut cover is determined by measuring from the inside surface of the dimple to the opposite 'flat' surface of the Nut Cover.

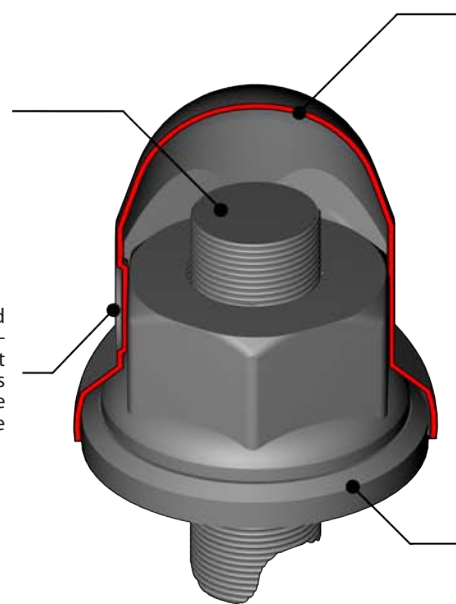

304 Stainless Steel - Our OEM-grade Nut Covers are designed to provide years of service without rusting or corroding, and the thick steel resists dents and dings better than the cheap imitators. 304 stainless is guaranteed never to rust.

Many of our popular models are also available in SuperPremium® Chrome for those looking for a classic chrome look.

With Flange - 33mm Lug Nuts (used on hub-piloted wheels) have an integral flange washer at the base. This feature requires a flange on the Nut Cover installed.

With Flange